

**MAINTENANCE &
TROUBLESHOOTING
MANUAL**

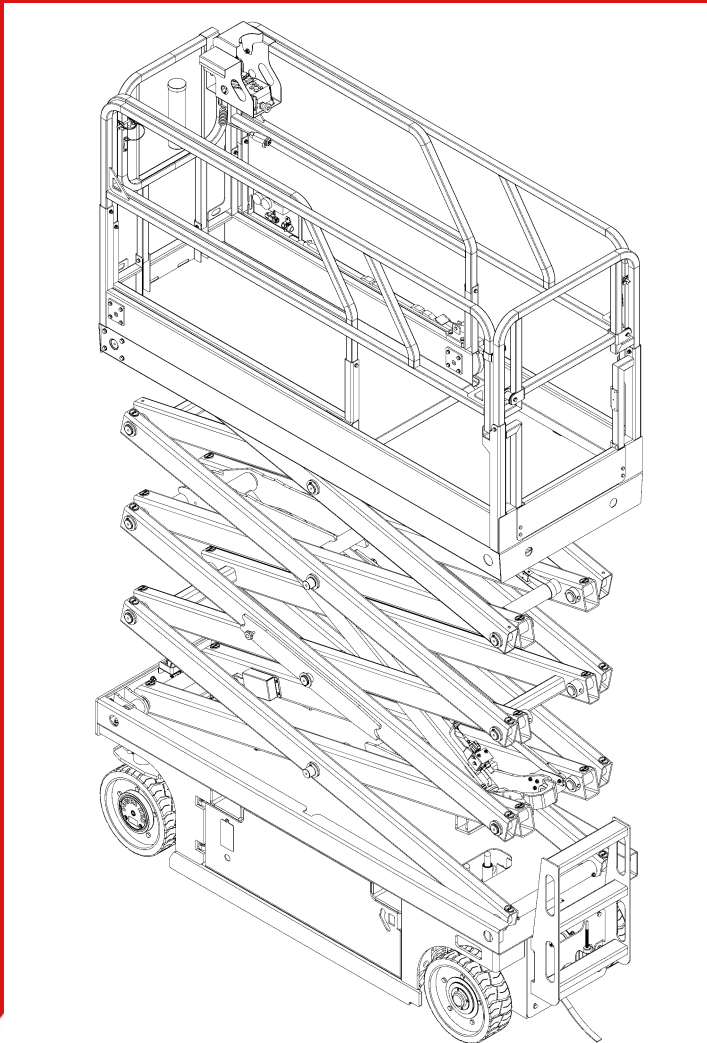

SCISSOR LIFT

TE Series

EL10-TE

EL8-TE

ELS LIFT

CE

**OUTPOWER
THE GRAVITY.**

Revision History

| REVISION NUMBER | DATE | UPDATE |
|-----------------|---------------|---|
| 01 | October 2022 | Specifications, General Safety, Location of Safety Indicators, Electrical Circuit, Hydraulic Circuit, Description of Symbols and Hazard Legends, Inspection of Symbols and Hazard Legends, For the Electric Motor Drive Model , Periodic Maintenance Schedule |
| 02 | November 2022 | Description of Symbols and Hazard Legends, Inspection of Symbols and Hazard Legends, General Safety, Location of Safety Indicators |
| 03 | January 2023 | Purpose of Uses, Personal Safety, Safety of the Work Area |
| 04 | December 2024 | All manual titles been updated. |
| 05 | March 2025 | The operator manual and the maintenance manual are separated. |
| | | |
| | | |
| | | |
| | | |
| | | |
| | | |
| | | |
| | | |
| | | |
| | | |
| | | |
| | | |

Important

Please read carefully and understand the safety principles and operating instructions before using this machine, and observe them.

Only trained and authorized persons are allowed to operate this machine.

This guide should be considered as an integral reference and should always accompany the machine.

The operator manual is a translation of the original instructions.

Safe operation of this product can be assured if you follow the operating instructions contained in this manual.

Please contact us if you have any questions.

Contact Details:

ELS Lift Makina Sanayi Ticaret A.Ş.

Organize Sanayi Bölgesi Lacivert Cadde No:11
16140 Nilüfer/Bursa/TÜRKİYE

Phone : +90 224 241 30 90

URL : info@elslift.com

www.elslift.com

aftersales@elslift.com

Owners, Users and operators:

We appreciate your choice of our machine for your application. Our number one priority is user safety, which is best achieved by our joint efforts. We feel that you make a major contribution to safety if you, as the equipment users and operators:

- 1- Comply with employer, job site and governmental rules.
- 2- Read, understand and follow the instructions in this and other manuals supplied with this machine.
- 3- Use good safe work practices in a commonsense way.
- 4- Only have trained / certified operators, directed by informed and knowledgeable supervision, running the machine. If there is anything in this manual that is not clear or which you believe should be added, please contact us.

CONTENTS

LIMITED OWNER WARRANTY 53

| | |
|---|----|
| Description..... | 5 |
| EL10-TE and EL8-TE | 5 |
| Maintenance Instructions..... | 7 |
| Maintenance Symbols Legend | 7 |
| Pre-delivery Preparation Report | 7 |
| Maintenance Schedule | 7 |
| Maintenance Inspection Report..... | 8 |
| Pre-delivery Preparation Report | 8 |
| Maintenance Inspection Report..... | 9 |
| Checklist A Procedures | 12 |
| Checklist B Procedures | 17 |
| Checklist C Procedures | 28 |
| Checklist D Procedures | 31 |
| Checklist E Procedures | 32 |
| Periodic Maintenance Schedule | 34 |
| Pre-Start Inspection Checklist | 36 |
| Pre-Delivery/Annual/Frequent Inspection Checklist | 38 |
| Fault Codes and Troubleshooting | 40 |
| Fault Codes and Troubleshooting | 43 |
| Fault Codes (6 Buttons)..... | 43 |
| Fault Descriptions and Troubleshooting (6 Buttons) | 45 |
| Electrical Circuit (4 Button) | 47 |
| Electrical Circuit (6 Button) | 48 |
| Hydraulic Circuit | 49 |
| Specifications..... | 50 |
| Draft Declaration of Conformity | 51 |
| Inspection and Repair Notes | 52 |

Manual

About this manual

ELS LIFT appreciates your choice of our machine for your application. Our number one priority is user safety, which is best achieved by our joint efforts. This book is an operation and daily maintenance manual for the user or operator of a ELS LIFT machine.

This manual should be considered a permanent part of your machine and should remain with the machine at all times. If you have any questions, contact ELS LIFT.

Intended Use and Familiarization Guide

The intended use of this machine is to lift personnel, including tools, and materials to an aerial work site. Before operating the machine, it's the operator's responsibility to read and understand this familiarization guide.

- ✓ Each person must be trained to operate a Mobile Elevating Work Platform (MEWP).
- ✓ Familiarization with the MEWP must be given to each person who is authorized, competent and trained.
- ✓ Only trained and authorized personnel should be permitted to operate the machine.
- ✓ The operator is responsible to read, understand, and obey the manufacturer's instructions and safety rules provided in the Operator's Manual.
- ✓ The Operator's Manual is located in the manual storage container, at the platform.

- ✓ For specific product applications, see Contacting The Manufacturer (ELS LIFT).

Contacting the Manufacturer

At times it may be necessary to contact ELS LIFT. When you do, be ready to supply the model number and serial number of your machine, along with your name and contact information.

Description

EL10-TE and EL8-TE

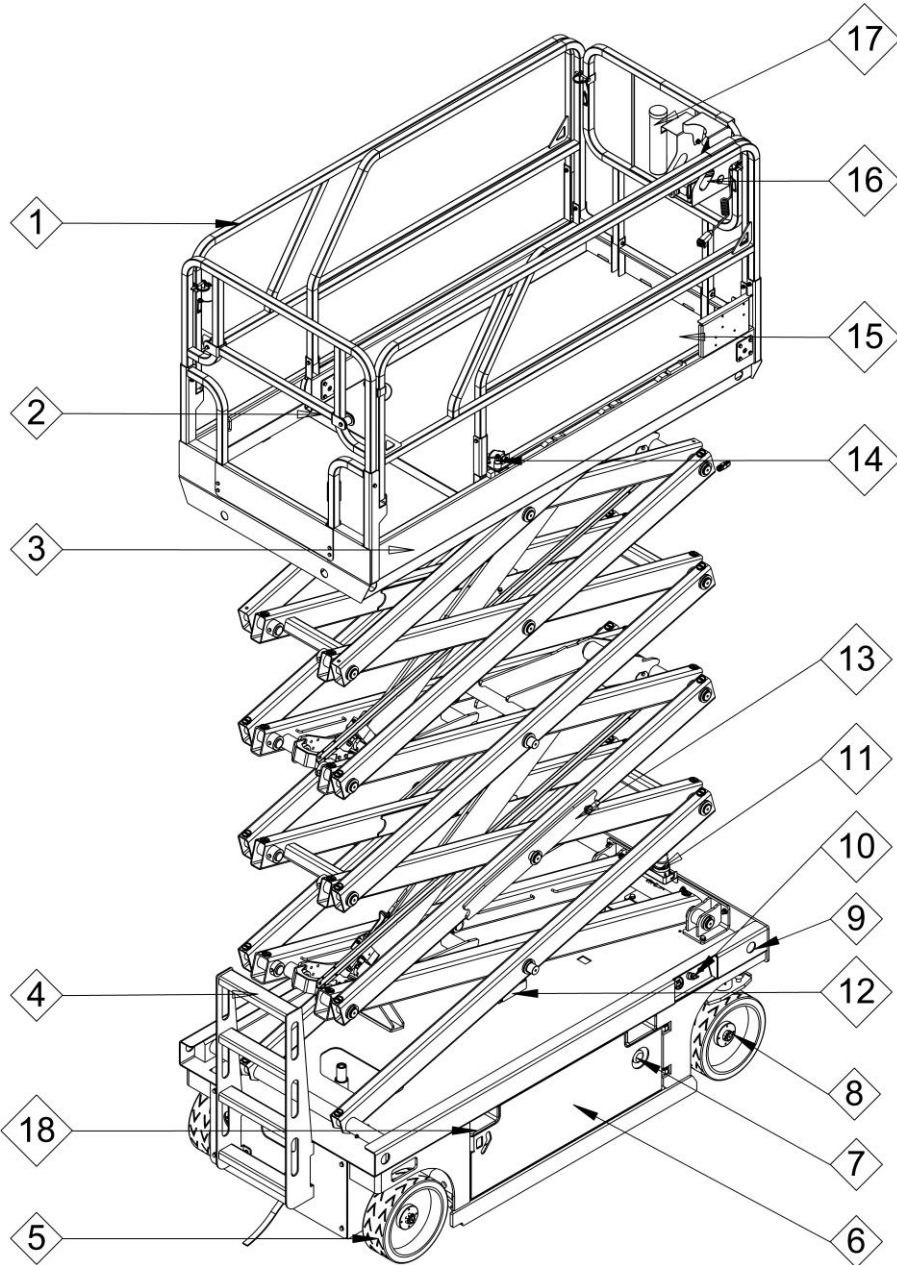

1. Platform Guide Rails
2. Platform Entry Gate
3. Platform
4. Platform Access Ladder
5. Driving Wheels
6. Batteries
7. Emergency Stop Button
8. Steer Wheels
9. Transport and Fixing Point
10. Ground Control Panel
11. Flashlight
12. Tilt Sensor
13. Maintenance Rod
14. Platform Extension Lock
15. Platform Extension
16. Platform Control Panel
17. Guide Storage Container
18. Forklift Pocket

Maintenance Instructions



Only the operator may perform the routine maintenance items specified in this manual.

Only qualified service technicians may carry out periodic and scheduled maintenance procedures.

Use only ELS Lift - approved replacement parts.

Maintenance Symbols Legend

NOTICE

The following symbols have been used in this manual to help communicate the intent of the instructions. When one or more of the symbols appear at the beginning of a maintenance procedure, it conveys the meaning below.



Indicates that tools will be required to perform this procedure.



Indicates that new parts will be required to perform this procedure.



Indicates that dealer service will be required to perform this procedure.

Pre-delivery Preparation Report

The pre-delivery preparation report contains checklists for each type of scheduled inspection.

Make copies of the Pre-delivery Preparation report to use for each inspection. Store completed forms as required.

Maintenance Schedule

There are five types of maintenance inspections that must be performed according to a schedule— daily, quarterly, semi-annually, annually, and two years. The Scheduled Maintenance Procedures Section and the Maintenance Inspection Report have been divided into five subsections — “A, B, C, D, and E”. Use the following chart to determine which group(s) of procedures are required to perform a scheduled inspection.

| Inspection | Checklist |
|----------------------------------|-----------|
| Daily or every 8 hours | A |
| Quarterly or every 250 hours | A+B |
| Semi-annually or every 500 hours | A+B+C |
| Annually or every 1000 hours | A+B+C+D |
| Two years or every 2000 hours | A+B+C+D+E |

Manual

Maintenance Inspection Report

The maintenance inspection report contains checklists for each type of scheduled inspection.

Make copies of the Maintenance Inspection Report to use for each inspection. Maintain completed forms for a minimum of 4 years or in compliance with your employer, jobsite and governmental regulations and requirements.

Pre-delivery Preparation Report

Fundamentals

It is the responsibility of the dealer to perform the Pre-delivery Preparation.

The Pre-delivery Preparation is performed prior to each delivery. The inspection is designed to discover if anything is apparently wrong with a machine before it is put into service.

A damaged or modified machine must never be used. If damage or any variation from factory delivered condition is discovered, the machine must be tagged and removed from service.

A qualified service technician, according to the manufacturer's specifications, may only make repairs to the machine.

Qualified service technicians, according to the manufacturer's specifications, shall perform scheduled maintenance inspections and the requirements listed in this manual.

Instructions

Use the operator's manual on your machine.

The Pre-delivery Preparation consists of completing the Pre-operation Inspection, the Maintenance items and the Function Tests.

Use this form to record the results. Place a check in the appropriate box after each part is completed. Follow the instructions in the operator's manual.

If any inspection receives an N, remove the machine from service, repair and re-inspect it. After repair, place a check in the R box.

Legend

Y = yes, completed

N = no, unable to complete

R = repaired

Comments

| Pre-Delivery Preparation | Y | N | R |
|------------------------------------|---|---|---|
| Pre-operation Inspection Completed | | | |
| Maintenance items Completed | | | |
| Function Tests Completed | | | |

| | |
|-------------------|--|
| Model | |
| Serial Number | |
| Date | |
| Machine Owner | |
| Inspector Company | |

Maintenance Inspection Report

| | |
|---------------------|--|
| Model | |
| Serial Number | |
| Date | |
| Hourmeter | |
| Machine Owner | |
| Inspector | |
| Inspector signature | |
| Inspector title | |
| Inspector Company | |

Instructions

- 1- Make copies of this report to use for each inspection.
- 2- Select the appropriate checklist(s) for the type of inspection to be performed.

| | | |
|--------------------------|----------------------------------|-----------|
| <input type="checkbox"/> | Daily or every 8 hours | A |
| <input type="checkbox"/> | Quarterly or every 250 hours | A+B |
| <input type="checkbox"/> | Semi-annually or every 500 hours | A+B+C |
| <input type="checkbox"/> | Annually or every 1000 hours | A+B+C+D |
| <input type="checkbox"/> | Two years or every 2000 hours | A+B+C+D+E |

- Place a check in the appropriate box after each inspection procedure is completed.
- Use the step-by-step procedures in this section to learn how to perform these inspections.
- If any inspection receives an “N”, tag and remove the machine from service, repair and re-inspect it. After repair, place a check in the “R” box.

Legend

Y = yes, completed

N = no, unable to complete

R = repaired

| CHECKLIST A | Y | N | R |
|---|----------|----------|----------|
| A-1 Inspect the manuals and decals | | | |
| A-2 Pre-operation inspection | | | |
| A-3 Check the batteries | | | |
| A-4 Check the hydraulic oil level | | | |
| A-5 Function tests | | | |
| A-6 Emergency Download Function | | | |
| A-7 Locking Mechanism and Spring Hinge on the Platform | | | |
| A-8 Seat Belt Anchor Locations Check | | | |
| Perform after 40 hours: | | | |
| A-9 30 day service | | | |
| CHECKLIST B | Y | N | R |
| B-1 Batteries | | | |
| B-2 Electrical wiring | | | |
| B-3 Tires and wheels | | | |
| B-4 Emergency stop button | | | |
| B-5 Key switch | | | |
| B-6 Horn (if equipped) | | | |
| B-7 Drive brakes | | | |
| B-8 Drive speed - stowed | | | |
| B-9 Drive speed - raised | | | |
| B-10 Drive speed - slow | | | |
| B-11 Hydraulic oil analysis | | | |
| B-12 Tank venting system | | | |
| B-13 Maintenance of the Area Where the Wedge Moves | | | |
| B-14 Test the pothole limit switches and the level sensor | | | |
| CHECKLIST C | Y | N | R |
| C-1 Platform overload (if equipped) | | | |
| C-2 Breather cap - models with optional oil | | | |
| CHECKLIST D | Y | N | R |
| D-1 Hydraulic filter | | | |
| D-2 Service Maintenance | | | |

Manual

| CHECKLIST E | Y | N | R |
|------------------------------|----------|----------|----------|
| E-1 Hydraulic oil | | | |
| E-2 Replacing Wheel Bearings | | | |

Checklist A Procedures

A-1

Inspect the Manuals and Decals

Maintaining the operator's manual in good condition is essential to safe machine operation. Manuals are included with each machine and should be stored in the container provided in the platform. An illegible or missing manual will not provide safety and operational information necessary for a safe operating condition.

In addition, maintaining all of the safety and instructional decals in good condition is mandatory for safe machine operation. Decals alert operators and personnel to the many possible hazards associated with using this machine. They also provide users with operation and maintenance information. An illegible decal will fail to alert personnel of a procedure or hazard and could result in unsafe operating conditions.

- Check to make sure that the operator's manual is present and complete in the storage container on the platform.
- Examine the pages of manual to be sure that they are legible and in good condition.

Result: The Operator's Manual is appropriate for the machine and the manual are legible and in good condition.

Result: The Operator's Manual is not appropriate for the machine or the manual is not in good condition or is illegible.

Result: Remove the machine from service until the manual is replaced.

The non-slip tapes attached to the machine's platform floor should not be removed. It is a precaution taken against the danger of slipping on the platform floor. If it is thought to be damaged, the anti-slip tapes should be replaced with new ones.

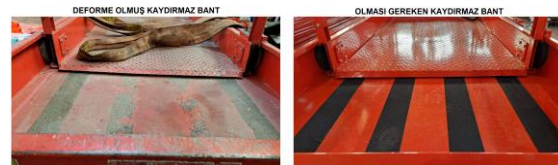

Open the Operator's Manual to the decals inspection section. Carefully and thoroughly inspect all decals on the machine for legibility and damage.

Result: The machine is equipped with all required decals, and all decals are legible and in good condition.

Result: The machine is not equipped with all required decals, or one or more decals are illegible or in poor condition. Remove the machine from service until the decals are replaced.

- Always return the manual to the storage container after use.

Note: Contact your authorized **ELS LIFT** distributor or **ELS LIFT** if replacement manuals or decals are needed.

A-2

Perform Pre-operation Inspection

Completing a Pre-operation Inspection is essential to safe machine operation. The Pre-operation Inspection is a visual inspection performed by the operator prior to each work shift. The inspection is designed to discover if anything is apparently wrong with a machine before the operator performs the function tests. The Pre-operation Inspection also serves to determine if routine maintenance procedures are required.

Complete information to perform this procedure is available in the appropriate operator's manual. Refer to the Operator's Manual on your machine.

A-3

Check the Batteries



Proper battery condition is essential to good machine performance and operational safety. Improper fluid levels or damaged cables and connections can result in component damage and hazardous conditions.

Note: This check is not required for machines with lithium batteries, sealed batteries, or Maintenance - free batteries.

The first point to check on the battery is the battery terminal area. If there is oxidation at the poles, the poles should be cleaned with hot water.

If use continues in an oxidized form, the battery or vehicle may malfunction due to melting at the terminal and problems in energy transmission.

The battery electrolyte level should be 1 or 1.5 cm above the plates. The plates must not come out of the water. The correct acid (electrolyte) level in the battery is a very important factor in terms of the durability and operating capacity of the battery.

If the acid level is too low, the lead plates remain at the top of the electrolyte liquid, the electrolyte level has gone below the lead plates. Corrosion occurs on the plates in this part. Battery failures and battery explosions may occur in such batteries.

If the battery has lost water, pure water sold in boxes is taken from the disintegrators and slowly and carefully poured pure water from the

Manual

battery element covers is added as follows. Tap water is not used, there is a lot of lime and mineral substances in tap water, these disrupt the structure of the battery electrolyte, pure water is free from lime and other minerals. Pure water is not drinkable.

Detailed explanations about battery maintenance can be viewed in the "Battery and Charger Instructions" section.

⚠ WARNING Electrocutation hazard: Contact with hot or live circuits may result in death or serious injury. Remove all rings, watches and other jewellery.

⚠ WARNING Bodily injury hazard: Batteries contain acid. Avoid spilling or contacting battery acid. Neutralize battery acid spills with baking soda and water.

- 1- Put on protective clothing and eyewear.
- 2- Be sure that the battery cable connections are tight and free of corrosion.
- 3- Be sure that the battery hold-down bars are secure.
- 4- Remove the battery vent caps.
- 5- Check the battery acid level. If needed, replenish with distilled water to the bottom of the battery fill tube. Do not overfill.
- 6- Install the vent caps.

A-4

Check the Hydraulic Oil Level

Maintaining the hydraulic oil at the proper level is essential to machine operation. Improper hydraulic oil levels can damage hydraulic components. Daily checks allow the inspector to identify changes in oil level that might indicate the presence of hydraulic system problems.

NOTICE Perform this procedure with the platform in the stowed position.

- 1- Visually inspect the sight of hydraulic oil level from the side of the hydraulic oil tank.

Result: The hydraulic oil level should be at the mark of the fuel tank.

- 2- Add oil if necessary. Do not overfill.

Customers shall choose the appropriate hydraulic oil according to the ambient temperature used.

Manual

A-5**Perform Function Tests**

Completing the function tests is essential to safe machine operation. Function tests are designed to discover any malfunctions before the machine is put into service. A malfunctioning machine must never be used. If malfunctions are discovered, the machine must be tagged and removed from service.

Complete information to perform this procedure is available in the appropriate operator's manual. Refer to the Operator's Manual on your machine.

A-6**Checking the Emergency Download Function**

If the machine needs to be lowered in an emergency, the emergency lowering procedure must be performed.

To perform the emergency lowering procedure, the emergency lowering handle is pulled outwards to ensure the machine platform is lowered safely.

**EMERGENCY LOWERING****A-7****Checking the Locking Mechanism and Spring Hinge on the Platform**

Before using the machine, it should be checked whether the lock mechanism on the platform is working properly. By opening and closing the balcony extension, it is ensured that the locking mechanism of the platform is working correctly. In addition, the spring hinge of the platform entrance door; Make sure that the door does not cause any problems when opening and closing, and that the door closes automatically. To maintain the hinges:

- Check the hinges for dirt and debris buildup, as these can cause clacking or grinding noises. Clean and lubricate properly if necessary.
- Check whether the door rubs against the platform when opening and closing. If so, tighten the screws on both sides of the hinge to make sure the door holds in place without any resistance.
- Make sure all screws on both sides of the hinge are securely tightened to prevent rough movement of the door. Also check for worn parts such as pins or bushings that may need to be replaced due to wear and tear over time.

Manual

A-8**Seat Belt Anchor Locations Check**

Seat belt attachment points must be checked before each use. The operator must wear a seat belt when using the machine on the platform.

Having secure seat belt locations ensures the operator's life safety in the event of a possible accident, allowing him to avoid the accident with minimal damage.

A-9**Perform 30 Day Service**

The 30-day maintenance procedure is a onetime procedure to be performed after the first 30 days or 40 hours of usage. After this interval, refer to the maintenance tables for continued scheduled maintenance.

Perform the following maintenance procedures:

- B-3 Inspect the Tires, Wheels and Castle Nut Torque

Checklist B Procedures

B-1

Inspect the Batteries



ELS LIFT requires that this procedure be performed every 250 hours or quarterly, whichever comes first.

Proper battery condition is essential to good machine performance and operational safety. Improper fluid levels or damaged cables and connections can result in component damage and hazardous conditions.

⚠ WARNING Electrocutation / burn hazard: Contact with electrically charged circuits could result in death or serious injury. Remove all rings, watches and other jewellery.

⚠ WARNING Bodily injury hazard: Batteries contain acid. Avoid spilling or contacting battery acid. Neutralize battery acid spills with baking soda and water.

- 3- Put on protective clothing and eyewear.
- 4- Release the battery pack latch and rotate the battery pack out and away from the chassis.
- 5- Be sure that the battery cable connections are free of corrosion.

Note: Adding terminal protectors and a corrosion preventative sealant will help eliminate corrosion on the battery terminals and cables.

- 6- Be sure that the battery retainers and cable connections are tight.
- 7- Fully charge the batteries. Allow the batteries to rest 24 hours before performing this procedure to allow the battery cells to equalize.

Models without maintenance-free or sealed batteries:

- 8- Remove the battery vent caps and check the specific gravity of each battery cell with a hydrometer. Note the results.
- 9- Check the ambient air temperature and adjust the specific gravity reading for each cell as follows:
 - Add 0.004 to the reading of each cell for every 5.5° C above 26.7°C.
 - Subtract 0.004 from the reading of each cell for every 5.5° C below 26.7°C.

Result: All battery cells display an adjusted specific gravity of 1.277 or higher. The battery is fully charged. Proceed to step 11.

Result: One or more battery cells display a specific gravity of 1.217 or below. Proceed to step 8.

- 10- Perform an equalizing charge OR fully charge the batteries and allow the batteries to rest at least 6 hours.

- 11- Remove the battery vent caps and check the specific gravity of each battery cell with a hydrometer. Note the results.

Result: All battery cells display a specific gravity of 1.277 or greater. The battery is fully charged. Proceed to step 11.

Result: The difference in specific gravity readings between cells is greater than 0.1 OR the specific gravity of one or more cells is less than 1.177. Replace the battery.

Manual

12- Check the ambient air temperature and adjust the specific gravity reading for each cell as follows:

- 5- Add 0.004 to the reading of each cell for every 5.5° C above 26.7°C.
- 6- Subtract 0.004 from the reading of each cell for every 5.5° C below 26.7°C.

13- Check the battery acid level. If needed, replenish with distilled water to 3 mm below the bottom of the battery fill tube. Do not overfill.

14- Install the vent caps and neutralize any electrolyte that may have spilled.

15- Check each battery pack and verify that the batteries are wired correctly.

16- Inspect the battery charger plug for damage or excessive insulation wear. Replace as required.

17- Connect the battery charger to a properly grounded 100 – 240 V / 30 – 60 Hz single phase AC power supply.

Result: The charger should operate and begin charging the batteries.

Result: If, simultaneously, the charger alarm sounds and the LEDs blink, correct the charger connections at the fuse and battery. The charger will then operate correctly and begin charging the batteries.

Note: For best results, use an extension of adequate size with a length no longer than 15m.

The following must be measured and recorded once the battery has been fully charged, after a waiting time of at least 12 hours:

- Total voltage
- Individual voltage of the block battery. If significant changes to previous.

Measurements or differences between the block batteries are identified, and then customer service must be contacted for further testing or repairs.

Note: If you have any further questions regarding the battery charger operation, please contact the ELS LIFT After Selling Department.

B-2**Inspect the Electrical Wiring**

ELS LIFT requires that this procedure be performed every 250 hours or quarterly, whichever comes first.

Maintaining electrical wiring in good condition is essential to safe operation and good machine performance. Failure to find and replace burnt, chafed, corroded or pinched wires could result in unsafe operating conditions and may cause component damage.

⚠ WARNING Electrocutation / burn hazard: Contact with electrically charged circuits could result in death or serious injury. Remove all rings, watches and other jewellery.

- 1- Inspect the underside of the chassis for damaged or missing ground strap(s).
- 2- Inspect the following areas for burnt, chafed, corroded and loose wires:
 - 1- Ground control panel
 - 2- Hydraulic power unit module tray
 - 3- Battery pack module tray
 - 4- Platform controls
- 3- Turn the key switch to ground control. Turn the ground Emergency Stop button

Manual

clockwise to the on position. Pull out the platform Emergency Stop button to the on position.

- 4- Raise the platform until the distance of the two sets of scissor at least 0.5 m.
- 5- Lift the maintenance bar, move it to the center of the scissor arm and rotate up to a vertical position.
- 6- Lower the platform until the maintenance bar rests securely on the link. Keep clear of the maintenance bar when lowering the platform.

⚠ WARNING Crushing hazard: Keep hands clear of the maintenance bar when lowering the platform.

- 7- Inspect the centre chassis area and scissor arms for burnt, chafed and pinched cables.
- 8- Inspect the following areas for burnt, chafed, corroded, pinched and loose wires:
 - 1- Scissor arms
 - 2- ECU to platform controls
 - 3- Power to platform wiring
- 9- Inspect for a coating of dielectric grease in the following locations:
 - Between the ECU and platform controls
 - All wire harness connectors to Level sensor
- 10- Raise the platform and return the maintenance bar to the stowed position.
- 11- Lower the platform to the stowed position and turn the machine off.

B-3**Inspect the Tires and Wheels (including castle nut torque)**

ELS LIFT requires that this procedure be performed every 250 hours or quarterly, whichever comes first.

Maintaining the tires and wheels in good condition is essential to safe operation and good performance. Tire and/or wheel failure could result in a machine tip-over. Component damage may also result if problems are not discovered and repaired in a timely fashion.

- 1- Check the tire surface and sidewalls for cuts, cracks, punctures and unusual wear.
- 2- Check each wheel for damage, bends and cracks.
- 3- Remove the cotter pin and check each castle nut for proper torque.

Manual

B-4**Test the Emergency Stop Button**

ELS LIFT requires that this procedure be performed every 250 hours or quarterly, whichever comes first.

A properly functioning Emergency Stop Button is essential for safe machine operation. An improperly operating Emergency Stop Button will fail to shut off power and stop all machine functions, resulting in a hazardous situation.

As a safety feature, selecting and operating the ground controls will override the platform controls, except the platform Emergency Stop Button.

- 1- Turn the key switch to ground control. Pull out the platform and ground Emergency Stop Button to the on position.
- 2- Push in the Emergency Stop Button at the ground controls to the off position.

Result: No machine functions should operate.

- 3- Turn the key switch to platform control. Pull out the platform and ground Emergency Stop button to the on position.
- 4- Push in the Emergency Stop Button at the platform controls to the off position.

Result: No machine functions should operate.

Note: The Emergency Stop Button at the ground controls will stop all machine operation, even if the key switch is switched to platform control.

B-5**Test the Key Switch**

ELS LIFT requires that this procedure be performed every 250 hours or quarterly, whichever comes first.

Proper key switch action and response is essential to safe machine operation. The machine can be operated from the ground or platform controls and the activation of one or the other is accomplished with the key switch. Failure of the key switch to activate the appropriate control panel could cause a hazardous operating situation.

Perform this procedure from the ground using the platform controls. Do not stand in the platform.

- 1- Pull out the platform and ground Emergency Stop button to the on position.
- 2- Turn the key switch to platform control.
- 3- Check the platform up/down function from the ground controls.

Result: The machine functions should not operate.

- 4- Turn the key switch to ground control.
- 5- Check the machine functions from the platform controls.

Result: The machine functions should not operate.

- 6- Turn the key switch to the off position.

Result: No function should operate.

Manual

B-6**Test the Horn (if equipped)**

ELS LIFT requires that this procedure be performed every 250 hours or quarterly, whichever comes first.

The horn is activated at the platform controls and sounds at the ground as a warning to ground personnel. An improperly functioning horn will prevent the operator from alerting ground personnel of hazards or unsafe conditions.

- 1- Turn the key switch to platform control. Pull out the platform and ground Emergency Stop button to the on position.
- 2- Push down the horn button at the platform controls.

Result: The horn should sound.

B-7**Test the Drive Brakes**

ELS LIFT requires that this procedure be performed every 250 hours or quarterly, whichever comes first.

Proper brake action is essential to safe machine operation. The drive brake function should operate smoothly, free of hesitation, jerking and unusual noise.

Perform this procedure with the machine on a firm level surface that is free of obstructions, with the platform extension deck fully retracted and the platform in the stowed position.

- 1- Mark a test line on the ground for reference.
- 2- Turn the key switch to platform control. Pull out the platform and ground Emergency Stop button to the on position.
- 3- Lower the platform to the stowed position.
- 4- Press the drive function select button.
- 5- Choose a point on the machine; i.e., contact patch of a tire, as a visual reference for use when crossing the test line.
- 6- Bring the machine to top drive speed before reaching the test line. Release the function button switch or the joystick when your reference point on the machine crosses the test line.
- 7- Measure the distance between the test line and your machine reference point.

Result: The machine stops within the specified braking distance. No action required.

Result: The machine does not stop within the specified braking distance.

Note: The brakes must be able to hold the machine on any slope it is able to climb.

- 1- Replace the brakes and repeat this procedure beginning with step 1.

| | |
|-----------------------------|-------------|
| Braking distance, maximum | |
| High range on paved surface | 61cm ± 30cm |

B-8

Test the Drive Speed – Stowed Position



ELS LIFT requires that this procedure be performed every 250 hours or quarterly, whichever comes first.

Proper drive functions are essential to safe machine operation. The drive function should respond quickly and smoothly to operator control. Drive performance should also be free of hesitation, jerking and unusual noise over the entire proportionally controlled speed range.

Perform this procedure with the machine on a firm, level surface that is free of obstructions.

- 1- Create start and finish lines by marking two lines on the ground 12.2 m apart.
- 2- Turn the key switch to platform control. Pull out the platform and ground Emergency Stop button to the on position.
- 3- Lower the platform to the stowed position.
- 4- Press the drive function select button.
- 5- Choose a point on the machine; i.e., contact patch of a tire, as a visual reference for use when crossing the start and finish lines.
- 6- Bring the machine to top drive speed before reaching the start line. Begin timing when your reference point on the machine crosses the start line.
- 7- Continue at full speed and note the time when your reference point on the machine passes over the finish line. Refer to specifications.

Test the Drive Speed - Raised Position

ELS LIFT requires that this procedure be performed every 250 hours or quarterly, whichever comes first.

Proper drive functions are essential to safe machine operation. The drive function should respond quickly and smoothly to operator control. Drive performance should also be free of hesitation, jerking and unusual noise over the entire proportionally controlled speed range.

Perform this procedure with the machine on a firm, level surface that is free of obstructions.

- 1- Create start and finish lines by marking two lines on the ground 12.2 m apart.
- 2- Turn the key switch to platform control. Pull out the platform and ground Emergency Stop button to the on position.
- 3- Press the lift function select button.
- 4- Press and hold the function enable button on the joystick.
- 5- Raise the platform approximately 2 m from the ground.
- 6- Press the drive function select button.
- 7- Choose a point on the machine; i.e., contact patch of a tire, as a visual reference for use when crossing the start and finish lines.
- 8- Bring the machine to top drive speed before reaching the start line. Begin timing when your reference point on the machine crosses the start line.
- 9- Continue at full speed and note the time when your reference point on the machine passes over the finish line. Refer to specifications.

Test the Slow Drive Speed

ELS LIFT requires that this procedure be performed every 250 hours or quarterly, whichever comes first.

Proper drive functions are essential to safe machine operation. The drive function should respond quickly and smoothly to operator control. Drive performance should also be free of hesitation, jerking and unusual noise over the entire proportionally controlled speed range.

Perform this procedure with the machine on a firm, level surface that is free of obstructions.

- 1- Create start and finish lines by marking two lines on the ground 12.2 m apart.
- 2- Turn the key switch to platform control. Pull out the platform and ground Emergency Stop button to the on position.
- 3- Lower the platform to the stowed position.
- 4- Press the slow speed select button.
- 5- Choose a point on the machine; i.e., contact patch of a tire, as a visual reference for use when crossing the start and finish lines.
- 6- Bring the machine to top drive speed before reaching the start line. Begin timing when your reference point on the machine crosses the start line.
- 7- Continue at full speed and note the time when your reference point on the machine passes over the finish line.

Manual

B-11**Perform Hydraulic Oil Analysis**

ELS LIFT requires that this procedure be performed every 250 hours or quarterly, whichever comes first.

Replacement or testing of the hydraulic oil is essential for good machine performance and service life. Dirty oil may cause the machine to perform poorly and continued use may cause component damage. Extremely dirty conditions may require oil changes to be performed more often.

Note: Before replacing the hydraulic oil, the oil may be tested by an oil distributor for specific levels of contamination to verify that changing the oil is necessary.

If the hydraulic oil is not replaced at the two-years inspection, test the oil quarterly. Replace the oil when it fails the test. See E-1, Test or Replace the Hydraulic Oil.

Checking the Hydraulic Oil Level

Improper hydraulic oil levels can damage hydraulic components. Maintaining the hydraulic oil at the proper level is essential to machine operation.

1. Make sure that the scissors of the machine is closed and on a firm, level surface.
2. Visually inspect the oil level in the hydraulic oil tank.
3. The hydraulic oil level should be as marked on the tank. Add if necessary. Do not overfill.

B-12**Inspect the Hydraulic Tank Cap Venting System**

ELS LIFT requires that this procedure be performed quarterly or every 250 hours, whichever comes first. Perform this procedure more often if dusty conditions exist.

A free-breathing hydraulic tank cap is essential for good machine performance and service life. A dirty or clogged cap may cause the machine to perform poorly. Extremely dirty conditions may require that the cap be inspected more often.

- 1- Remove the breather cap from the hydraulic tank.
- 2- Check for proper venting.

Result: Air passes through the breather cap.

Result: If air does not pass through the cap, clean or replace the cap. Proceed to step three.

Note: When checking for tank cap venting, air should pass freely through the cap.

- 3- Using a mild solvent, carefully wash the cap venting system. Dry using low-pressure compressed air. Repeat step 2.
- 4- Install the breather cap on to the hydraulic tank.

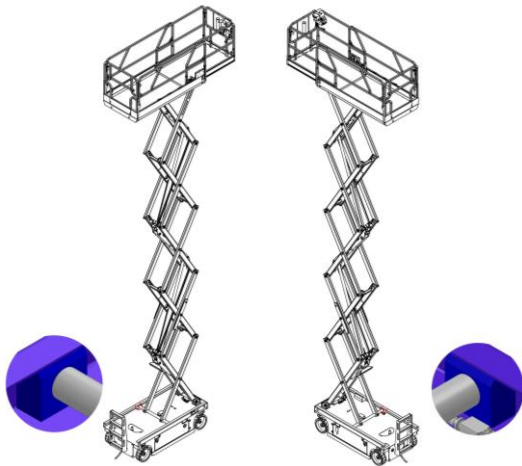

Maintenance of the Area Where the Wedge Moves

ELS LIFT requires that this procedure be performed every 250 hours or quarterly, whichever comes first.

It is very important to grease the area where the machine's chock moves, as this will maintain the performance and lifespan of the machine. Dirty grease will lead to poor performance of the machine. Additionally, continued use of dirty grease may cause the machine to shake and make abnormal noises when the machine is lifted. When the area where the wedge moves is dry, grease needs to be added.

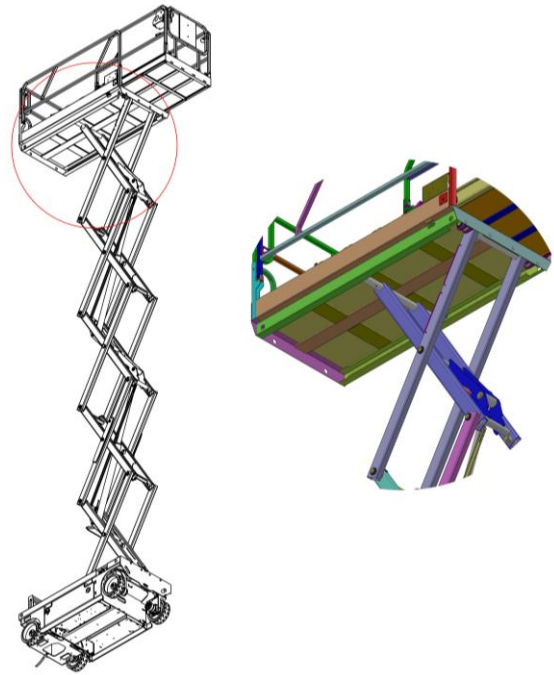

Recommendation: Check the grease every week, make sure there is enough clean grease in the slide area.

⚠ WARNING Do not add hydraulic oil, engine oil, diesel etc.

Manual

B 14**Test the Pothole Limit Switches and the Level Sensor**

ELS LIFT requires that this procedure be performed every 250 hours or quarterly, whichever comes first.

Maintaining the limit switches is essential to safe operation and good machine performance. Operating the machine with a faulty limit switch could result in reduced machine performance and a potentially unsafe operating condition.

Perform these procedures with the machine on a firm, level surface that is free of obstructions.

Level Sensor

1. Remove the platform controls from the platform.
2. Turn the key switch to platform control. Pull out the platform and ground Emergency Stop button to the on position.
3. Press the drive function select button.
4. Move the machine on to a grade, which exceeds the rating of the level sensor. Refer to the serial label on the machine.
5. Press the lift function select button. Standing on the up-hill side of the machine, attempt to raise the platform to approximately 2.4 m.

Result: The LED readout screen shows code LL, an alarm sounds, and the machine stops lifting after the pothole guards are deployed. The machine is functioning properly.

Result: The LED readout screen does not show code LL, the alarm does not sound and the machine will continue to lift the platform after the

pothole guards are deployed. Adjust or replace the level sensor.

- 6 Press the drive function select button. Standing on the up-hill side of the machine, attempt to steer and drive the machine.

Result: The LED readout screen shows code LL, an alarm sounds, and the machine will not steer or drive. The machine is functioning properly.

Result: The LED readout screen does not show code LL, the alarm does not sound and the steer and drive functions operate. Adjust or replace the level sensor.

Pothole Limit Switches

- 7- Lower the platform to the stowed position. Move the machine on to a firm, level surface.
- 8- Place a wooden block approximately 5 cm tall under the right pothole guard.
- 9- Press the lift function select button. Attempt to raise the platform approximately 2.4 m.

Result: The pothole guard contacts the block and does not fully deploy, the LED readout screen shows code 18, an alarm sounds and the platform will lift to 2.4 m or beyond. The machine is functioning properly.

Result: The pothole guard contacts the block and does not fully deploy, the LED readout screen does not show code 18, the alarm does not sound and the machine will continue to lift the platform after the pothole guards are deployed. Adjust or replace the pothole limit switch.

- 10- Press the drive function select button. Attempt to steer or drive the machine.

Manual

Result: The LED readout screen shows code 18, an alarm sounds, and the machine will not steer or drive. The machine is functioning properly.

Result: The LED readout screen does not show code 18, the alarm does not sound and the steer and drive functions operate. Adjust or replace the pothole limit switch.

- 11- Lower the platform to the stowed position and remove the block under the right pothole guard.
- 12- Repeat this procedure beginning with step 10 for the left pothole guard.
- 13- Lower the platform to the stowed position; remove the block under the left pothole guard.
- 14- Turn off the machine.

Checklist C Procedures

C-1

Test the Platform Overload System (if equipped)



ELS LIFT requires that this procedure be performed every 500 hours or six months, whichever comes first or when the machine fails to lift the maximum rated load.

Testing the platform overload system regularly is essential to safe machine operation.

Continued use of an improperly operating platform overload system could result in the system not sensing an overloaded platform condition. Machine stability could be compromised resulting in the machine tipping over.

The platform overload system is designed to prevent machine operation in the event the platform is overloaded. Models equipped with the platform overload option are provided with two additional machine control components: the overload pressure sensor and the platform The overload pressure sensor, located at the valve of the lift cylinder, is used to determine the pressure inside the lift cylinder.

The platform height sensor, located at the steer end of the chassis, battery side, is used to determine the height of the platform.

The overload pressure sensor and the platform height sensor provide necessary information to determine the load in the platform.

Note: The overload system will not measure loads at or below the height of the Down Limit.

Note: Perform this test from the ground with the platform controller. Do not stand in the platform.

⚠ WARNING Perform this procedure with the machine on a firm, level surface.

- 1- Turn the key switch to platform controls. Pull out the platform and ground Emergency Stop button to the on position.
- 2- Determine the maximum platform capacity.
- 3- Using a suitable lifting device, place an appropriate test weight equal to the maximum platform capacity in the center of the platform floor. Raise the platform.

Result: During operation, the overload alarm does not sound. The machine operates normally condition.

Result: During operation, the overload alarm sound. The machine calibrate the overload system.

- 4- The platform should lower to the stowed position
- 5- Add an additional weight to the platform not to exceed 20% of the maximum rated load. Raise the platform.

Result: The overload alarm at the platform controls sound, indicating a normal condition.

Result: The overload alarm at the platform controls does not sound. Calibrate the platform overload system.

- 6- Test all machine functions from the platform controls.

Result: All platform control functions should not operate.

Manual

- 7- Turn the key switch to ground control.
- 8- Test all machine functions from the ground controls
- Result:** All ground control functions should not operate.
- 9- Lift the test weight off the platform floor using a suitable lifting device.
- Result:** The overload alarm at the platform controls should not sound, indicating a normal condition.
- Result:** The overload alarm at the platform controls sounds. Calibrate the platform overload system.
- 10- Test all machine functions from the ground controls.
- Result:** All ground control functions should operate.
- 11- Turn the key switch to platform control.
- 12- Test all machine functions from the platform controls.
- Result:** All platform control functions should operate.

NOTICE

Where determined standards are not applied, sound levels are the most appropriate method for machinery should be measured using. When sound emission values indicate uncertainties, values around these values should be specified. During the measurement, the working conditions of the machines and the measurement methods used must be defined.

In case of unidentified workplace(s), a weighted sound pressure at a height of 1.6 m from the access platform or floor and 1 m from the surface on the machinery distance should be measured. The position and value of the greatest sound pressure should be indicated.

The sound emissions of the machines should not exceed 70 dBA. This is stated in the table in the "Specifications" section on page 92.

Replace the Hydraulic Tank Breather Cap



ELS LIFT requires that this procedure be performed every 500 hours or semi-annually, whichever comes first.

The hydraulic tank is a vented-type tank. The breather cap has an internal air filter that can become clogged or, over time, can deteriorate. If the breather cap is faulty or improperly installed, impurities can enter the hydraulic system which may cause component damage. Extremely dirty conditions may require that the cap be inspected more often.

- 1- Remove and discard the hydraulic tank breather cap.
- 2- Install a new cap on to the tank.

Checklist D Procedures

D-1

Replace the Hydraulic Tank Return Filter Element



ELS LIFT requires that this procedure be performed every 1000 hours or annually, whichever comes first.

Replacement of the hydraulic tank return filter is essential for good machine performance and service life. A dirty or clogged filter may cause the machine to perform poorly and continued use may cause component damage. Extremely dirty conditions may require that the filter be replaced more often.

⚠ WARNING Beware of hot oil. Contact with hot oil may cause severe burns.

- 1- Clean the area around the oil filter. Remove the filter with an oil filter wrench.
- 2- Apply a thin layer of oil to the new oil filter gasket.
- 3- Install the new filter and tighten it securely by hand.
- 4- Use a permanent ink marker to write the date and number of hours from the hour meter on to the filter.
- 5- Turn the key switch to ground control. Pull out the platform and ground Emergency Stop button to the on position.
- 6- Activate and hold the platform up toggle switch.
- 7- Inspect the filter and related components to be sure that there are no leaks.
- 8- Clean up any oil that may have spilled.

D-2

Service Maintenance

This procedure should be performed every 1000 hours or annually (whichever occurs first).

This maintenance is carried out in order to constantly maintain the functionality of the parts included in the equipment of the machine and to keep the overall performance of the vehicle at the maximum level. When done regularly, it extends the life of the engine and helps the machine continue to operate smoothly.

Checklist E Procedures

E-1

Test or Replace the Hydraulic Oil



ELS LIFT requires that this procedure be performed every 2000 hours or every two years, whichever comes first.

Replacement or testing of the hydraulic oil is essential for good machine performance and service life. Dirty oil may cause the machine to perform poorly and continued use may cause component damage. Extremely dirty conditions may require oil changes to be performed more often.

NOTICE

Before replacing the hydraulic oil, the oil may be tested by an oil distributor for specific levels of contamination to verify that changing the oil is necessary.

If the hydraulic oil is not replaced at the two-years inspection, test the oil quarterly. Replace the oil when it fails the test.

Note: Perform this procedure with the platform in the stowed position.

1- Shut down the battery pack from the machine.

⚠ WARNING **Electrocution / burn hazard:** Contact with electrically charged circuits could result in death or serious injury. Remove all rings, watches and other jewellery.

- 2- Open the power unit module tray.
- 3- Remove the oil drain plug at bottom.
- 4- Drain all of the oil into a suitable container.
- 5- Tag and shut down the hydraulic tank return line from the hydraulic filter head and remove the line from the tank. Cap the fitting on the filter head.
- 6- Tag and shut down the hydraulic pump inlet line and remove the line from the tank. Cap the fitting on the pump.
- 7- Remove the hydraulic tank retaining fasteners and remove the hydraulic tank from the machine.

⚠ WARNING **Bodily injury hazard:** Spraying hydraulic oil can penetrate and burn skin. Loosen hydraulic connections very slowly to allow the oil pressure to dissipate gradually. Do not allow oil to squirt or spray.

- 8- Clean up any oil that may have spilled. Properly discard the used oil.
- 9- Clean the inside of the hydraulic tank using a mild solvent. Allow the tank to dry completely.
- 10- Install a new filter on to the tank.
- 11- Tighten the drain plug. Torque to specification.

Torque specifications

- Hydraulic tank drain plug, dry 4.5 Nm
 - Hydraulic tank drain plug, lubricated 3.4 Nm
- 12- Install the hydraulic tank, install, and tighten the hydraulic tank retaining fasteners. Torque to specification.

Manual

Torque specifications

- Hydraulic tank retaining fasteners, dry
4 Nm
 - Hydraulic tank drain plug, lubricated
2.9 Nm
- 13- Install the hydraulic pump inlet line into the tank. Install the fitting on to the pump and torque.
 - 14- Install the hydraulic pump return line into the tank. Install the fitting on to the hydraulic filter head and torque.
 - 15- Fill the tank with hydraulic oil until the fluid is full in the hydraulic tank. Do not overfill.
 - 16- Activate the pump to fill the hydraulic system with oil and bleed the system of air.

 **WARNING** Component damage hazard:
The pump can be damaged if operated without oil. Be careful not to empty the hydraulic tank while in the process of filling the hydraulic system. Do not allow the pump to cavitate.

E-2**Replacing Wheel Bearings**

This procedure should be performed every 2000 hours or every two years, whichever occurs first.

Wheel bearings must be replaced as the machine operates continuously. Wheel bearings are important components of a vehicle's braking, steering and suspension systems. It is the component that makes the wheel turn. Bearings are tightly packed in a waterproof, sealed I metal ring filled with grease.

Wheel bearings must be replaced at service.

Periodic Maintenance Schedule

| Periodic Maintenance and Inspection | Daily | Every 50 hours | Every 250 hours | Every 500 hours | Every 1000 hours | Every 2000 hours |
|---|-------|----------------|-----------------|-----------------|------------------|------------------|
| Hydraulic oil | • | | | | | |
| Batteries | • | | | | | |
| Battery Charge Level | • | | | | | |
| Sealing of Connectors and Batteries | • | | | | | |
| Hydraulic Oil Filter | • | | | | | |
| Emergency Lowering Function | • | | | | | |
| Checking the Locking Mechanism and Spring Hinge on the Platform | • | | | | | |
| Seat Belt Anchor Locations Check | • | | | | | |
| Clogged Cartridge of the Hydraulic Oil Filter | | • | | | | |
| Battery Cable Condition | | • | | | | |
| Screws and Bolts | | • | | | | |
| Motor Mounting Screw | | • | | | | |
| Tire Mounting Screw | | • | | | | |
| Hydraulic Oil Filter Cartridge | | | • | | | |
| Battery Charger Connection | | | • | | | |
| Battery Water Levels | | | • | | | |
| Electrical Wiring | | | • | | | |
| Tires and Wheels | | | • | | | |
| Emergency Stop | | | • | | | |
| Key Switch | | | • | | | |
| Horn | | | • | | | |
| Drive Brakes | | | • | | | |
| Drive Speed – Stowed Position | | | • | | | |

Manual

| | | | | | | |
|---|--|--|---|---|---|---|
| Drive Speed – Raised Position | | | . | | | |
| Slow Drive Speed | | | . | | | |
| Hydraulic Oil Analysis | | | . | | | |
| Hydraulic Tank Cap Venting System | | | . | | | |
| Maintenance of the Area Where the Wedge Moves | | | . | | | |
| Pothole Limit Switches and the Level Sensor | | | . | | | |
| Platform Overload System | | | | . | | |
| Hydraulic Tank Breather Cap | | | | . | | |
| Draining the Hydraulic Oil Tank | | | | | . | |
| Service Maintenance | | | | | . | |
| Cleaning the Carbon Brush of the Hydraulic Unit Motor | | | | | . | |
| Replacing Wheel Bearings | | | | | | . |
| Replacement of Electrical Cables and Hydraulic Hoses | | | | | | . |

Pre-Start Inspection Checklist

| PRE-START INSPECTION CHECKLIST | | | | |
|---|----------|----------|----------|------------|
| <i>Y-Yes/Acceptable N-No/Unacceptable R-Repaired N/A-Not Equipped</i> | Y | N | R | N/A |
| VISUAL INSPECTIONS | | | | |
| Ensure that all parts are securely attached and there are no loose or missing components. | | | | |
| Verify that all warning, instructional, and informational labels are clearly visible and legible. | | | | |
| Inspect the platform rails for any visible signs of damage, bending, or deformation. | | | | |
| Verify that all control buttons, switches, and emergency stop mechanisms are operational and responsive. | | | | |
| Check all electrical cables and wires for signs of wear, fraying or disconnection. | | | | |
| Inspect hydraulic fittings and connections for tightness and proper sealing to prevent leaks. | | | | |
| Check for any oil or fluid stains around hoses, as this could indicate a leak. | | | | |
| Conduct a general inspection of the overall structural integrity of the platform, frame, and base. | | | | |
| Ensure the platform is level and stable before use. | | | | |
| Inspect wheels and axles to ensure smooth operation and no signs of cracking or excessive wear. | | | | |
| FUNCTIONAL TESTS | | | | |
| The gate closes automatically, latches securely, and moves smoothly without manual intervention. | | | | |
| Test all switches and push buttons to ensure correct operation. Confirm all platform control systems are responsive. | | | | |
| Pressing the emergency stop should immediately halt all movement and power operations. | | | | |
| Verify that the button toggles between drive mode and steering mode correctly. Ensure proper response in both modes. | | | | |
| The Up/Down button should raise and lower the platform smoothly. | | | | |
| Ensure the joystick returns to neutral position. The joystick should allow forward/reverse movement and function correctly in drive mode. | | | | |
| The enable trigger must be activated for joystick-controlled movement. Ensure the system only operates when the trigger is engaged. | | | | |
| The rocker switch should allow smooth control of front wheel movement (left/right). Ensure accurate steering with no jerky movements. | | | | |

Manual

| | | | | |
|--|--|--|--|--|
| The horn should sound loudly and clearly when the button is pressed, functioning as an emergency or warning signal. | | | | |
| Verify that all base control switches and push buttons function properly. Confirm smooth transition between control modes. | | | | |
| Confirm that the vehicle moves at slow speed when elevated, with the platform remaining stable without excessive tilting or movement. | | | | |
| Verify that all base control switches and push buttons function properly. Confirm smooth transition between control modes. | | | | |
| The key switch should toggle between platform control, ground control, or off. Ensure correct system operation based on switch position. | | | | |
| The rocker switch should raise and lower the platform smoothly. Confirm smooth elevation and descent with no stuttering. | | | | |
| The descent/tilt alarm should activate when the platform descends or tilts beyond safe limits. Ensure alarm sounds audibly. | | | | |
| Ensure front wheels rotate freely without obstruction. Verify proper wheel alignment and securely tightened lug nuts. | | | | |
| Brakes should engage immediately when the joystick is released. Verify that the brakes hold the unit on a slope. Ensure proper brake disengagement and alarm sounds. | | | | |
| The pothole guards should deploy automatically and lock securely when the platform is raised. | | | | |
| Ensure the platform does not elevate if the pothole guards are obstructed or improperly deployed. Confirm proper visual or audible alerts for malfunction. | | | | |

Pre-Delivery/Annual/Frequent Inspection Checklist

| PRE-DELIVERY/ANNUAL/FREQUENT INSPECTION CHECKLIST | | | | |
|---|----------|----------|----------|------------|
| Y-Yes/Acceptable N-No/Unacceptable R-Repaired N/A-Not Equipped | Y | N | R | N/A |
| CHASSIS | | | | |
| Ensure welds are intact, with no cracks or breaks for structural integrity. | | | | |
| Check slide tracks for wear, dents, or damage that may affect operation. | | | | |
| Verify that frame bolts are tight to prevent looseness or instability. | | | | |
| Confirm pump is securely mounted to avoid movement or malfunctions. | | | | |
| Ensure DC drive motors are tightly mounted and securely connected. | | | | |
| Ensure batteries are fully charged and ready for use. | | | | |
| WHEELS | | | | |
| Ensure snap rings are properly installed and secure. | | | | |
| Confirm bolts and nuts are tightly secured for safety. | | | | |
| SCISSORS | | | | |
| Ensure scissor mechanism welds are intact and free of cracks. | | | | |
| Inspect beam members for bending or deformation. | | | | |
| Ensure rollers function smoothly and without obstruction. | | | | |
| Verify retaining rings are securely placed on pivots. | | | | |
| Confirm maintenance locks are stored and connected properly. | | | | |
| Ensure scissor beam tube bolts are tight and secure. | | | | |
| PLATFORM | | | | |
| Check rails for bending or damage; ensure they are straight and secure. | | | | |
| Inspect platform for broken or cracked welds. | | | | |
| Ensure rails are securely installed and positioned. | | | | |
| Verify the 110V outlet is safe and functioning. | | | | |
| Ensure entrance gate operates smoothly and easily. | | | | |
| DECALS | | | | |
| Ensure decals are clear, readable, and not damaged. | | | | |
| Verify weight capacity decals match the manufacturer’s specifications. | | | | |
| Confirm decals are in the correct locations and meet safety compliance. | | | | |
| RAILS/EXTENDING PLATFORM | | | | |
| Ensure the platform extends smoothly without resistance. | | | | |
| Verify cables are properly positioned and secure. | | | | |
| Ensure platform locks securely in both stowed and extended positions. | | | | |
| FUNCTIONS | | | | |
| Ensure all functions (driving, elevating, steering) are operational. | | | | |
| Confirm pothole guards deploy automatically when raised. | | | | |

Manual

| | | | | |
|---|--|--|--|--|
| Verify emergency stop button halts operation when activated. | | | | |
| Ensure slow-speed mode activates with pothole bars deployed. | | | | |
| Check that pothole interlock prevents movement over obstructions. | | | | |
| BRAKES | | | | |
| Ensure brakes function correctly and stop the unit safely. | | | | |
| EMERGENCY DOWN | | | | |
| Ensure emergency down function is operational for platform descent. | | | | |
| WIRING | | | | |
| Verify switches are securely mounted and connected. | | | | |
| Ensure contactors are securely mounted without loose connections. | | | | |
| Confirm terminal connections are tight with no exposed wires. | | | | |
| OIL | | | | |
| Ensure oil level is 1 inch from the top when the platform is stowed. | | | | |
| OTHER | | | | |
| Inspect hoses for leaks, wear, or damage to prevent system failure. | | | | |
| Verify fittings are secure and free from leaks. | | | | |
| Confirm battery charger is mounted and operational. | | | | |
| Ensure elevation function is disabled when unit is tilted past the specified angle. | | | | |
| Check warning horn is operational. | | | | |
| Verify hour meter works for maintenance tracking. | | | | |
| Ensure battery indicator provides accurate charge level information. | | | | |
| Confirm the operator's manual is available for reference. | | | | |
| Verify overload light and alarm are functional (annual inspection for CE Lifts) | | | | |

Fault Codes and Troubleshooting

Fault Codes (4 Buttons)

| Display | Description | Machine Behaviour |
|---------|---|---|
| 01 | System Start-up Failure | All Functions are Disabled |
| 02 | System Communication Error | All Functions are Disabled |
| 03 | Invalid Mode Fault | All Functions are Disabled |
| 12 | Toggle Switch Open at Start-up Fault | All Functions are Disabled |
| 18 | Pothole Guard Fault | Lift and Drive Disabled |
| 31 | Pressure Sensor Fault | All Functions are Disabled |
| 32 | Angle Sensor Fault | All Functions are Disabled |
| 35 | Invalid Data Stored in ECU Even After Calibration | Warning Only |
| 38 | No or Partial Calibration When Load Detection Function is Enabled | Warning Only |
| 42 | Left Turn Switch Pressed at Start-up Fault | Functions are Enabled |
| 43 | Right Turn Switch Pressed at Start-up Fault | Functions are Enabled |
| 46 | Joystick Trigger Pressed at Start-up Fault | All Functions are Disabled |
| 47 | Joystick not in Normal Position at Start-up Fault | When the Platform is raised, Walking Speed is Lower |
| 52 | Forward Drive Coil Fault | Lift and Drive Disabled |
| 53 | Reverse Drive Coil Fault | Lift and Drive Disabled |
| 54 | Platform Up Coil Fault | Lift and Drive Disabled |
| 55 | Platform Down Coil Fault | Lift and Drive Disabled |
| 56 | Right Turn Coil Fault | Lift and Drive Disabled |
| 57 | Left Turn Coil Fault | Lift and Drive Disabled |
| 58 | General Brake Coil Fault | Lift and Drive Disabled |
| 68 | Low Voltage Fault | All Functions are Disabled |
| 80 | 80% of Lifting Capacity is Loaded | Warning Only |
| 90 | 90% of Lifting Capacity is Loaded | Warning Only |
| 99 | 99% of Lifting Capacity is Loaded | Warning Only |
| OL | Platform Overload Fault | All Functions are Disabled |
| LL | Predefined Slope Limits Exceeded | Lift and Drive Disabled |

Fault Descriptions and Troubleshooting (4 Buttons)

| Display | Description |
|---------|--|
| 01 | System Start-up Failure: Main control card may be defective, replace. |
| 02 | System Communication Error: Check the communication cables and other cable connections. If problem persists, replace the control box or the main control card. |
| 03 | Invalid Operating Mode Fault: Set the proper operating mode for this machine. |
| 12 | Toggle Switch Open at Start-up Fault: Check the toggle switch cables, check if toggle switch is stuck. |
| 18 | Pothole Guard Fault: Check if pothole guard skirts are deployed. Check the pothole limit switches and cables. Check the lower limit switches and cables. |
| 31 | Pressure Sensor Fault: Check the sensor and its connections. In addition, make sure that the correct option for load detection is selected. |
| 32 | Angle Sensor Fault: Check the sensor and its connections. In addition, make sure that the correct option for load detection is selected. |
| 35 | Invalid Data Stored in ECU Even After Calibration: Repeat the calibration procedure properly. |
| 38 | No or Partial Calibration When Load Detection Function is Enabled: Be sure that sensors are functional and repeat the calibration procedure. |
| 42 | Left Turn Switch Pressed at Start-up Fault: Be sure that the left turn switch on the joystick is not depressed externally. If not depressed, consider replacing the joystick or the control box. |
| 43 | Right Turn Switch Pressed at Start-up Fault: Be sure that the right turn switch on the joystick is not depressed externally. If not depressed, consider replacing the joystick or the control box. |
| 46 | Joystick Trigger Pressed at Start-up Fault: Be sure that the Joystick trigger is not depressed externally. Also, check the neutral area parameters. If not depressed, consider replacing the joystick or the control box. |
| 47 | Joystick not in Normal Position at Start-up Fault: Be sure that the joystick is at neutral (upright) axis. Check the neutral area parameter settings in the LabVIEW software. If parameter settings are correct, replace the joystick or the control box. |
| 52 | Forward Drive Coil Fault: Check coil cable and terminal connections, make sure that they are tight. If there is no problem, check if the coil is in open- or short-circuit condition. |
| 53 | Reverse Drive Coil Fault: Check coil cable and terminal connections, make sure that they are tight. If there is no problem, check if the coil is in open- or short-circuit condition. |
| 54 | Platform Up Coil Fault: Check coil cable and terminal connections, make sure that they are tight. If there is no problem, check if the coil is in open- or short-circuit condition. |
| 55 | Platform Down Coil Fault: Check coil cable and terminal connections, make sure that they are tight. If there is no problem, check if the coil is in open- or short-circuit condition. |

Manual

| | |
|----|---|
| 56 | Right Turn Coil Fault: Check coil cable and terminal connections, make sure that they are tight. If there is no problem, check if the coil is in open- or short-circuit condition. |
| 57 | Left Turn Coil Fault: Check coil cable and terminal connections, make sure that they are tight. If there is no problem, check if the coil is in open- or short-circuit condition. |
| 58 | General Brake Coil Fault: Check coil cable and terminal connections, make sure that they are tight. If there is no problem, check if the coil is in open- or short-circuit condition. |
| 68 | Low Voltage Fault: Check the battery voltage, charge the batteries if necessary. Check battery connections, make sure that terminals are tight. Check the voltage supplied to the main control card and control box. |
| 80 | 80% of Lifting Capacity is Loaded: Weight on the platform is near the maximum load capacity. Do not load extra weight. Near maximum limit. Do not load extra weight. |
| 90 | 90% of Lifting Capacity is Loaded: Weight on the platform is near the maximum load capacity. Do not load extra weight. |
| 99 | 99% of Lifting Capacity is Loaded: Weight on the platform is near the load limit. Do not load extra weight. |
| OL | Platform Overload Fault: Remove the excessive load from the platform. |
| LL | Predefined Slope Limits Exceeded: If the machine is on a slope, move it to a level surface. If the machine is on a level surface, check the tilt sensor and its connections. |

Fault Codes and Troubleshooting

Fault Codes (6 Buttons)

| Display | Description | Machine Behaviour |
|---------|--|------------------------------|
| 01 | System Initialization Fault | All Functions are Disabled |
| 02 | System Communication Error | All Functions are Disabled |
| 03 | Invalid Mode Fault | All Functions are Disabled |
| 04 | Invalid machine code | All Functions are Disabled |
| 09 | Invalid Function Configuration Setting Fault | All Functions are Disabled |
| 12 | Chassis Toggle Switch ON at Power-Up Fault | Disable Chassis Control |
| 18 | Pothole Guard Fault | Lift and Drive Disabled |
| 27 | Lift Down Coil Fault (only for proportional-valve) | Lift and Drive Disabled |
| 31 | Pressure Sensor Fault | All Functions are Disabled |
| 32 | Angle Sensor Fault | All Functions are Disabled |
| 35 | Invalid Data Stored in ECU Even After Calibration | Warning Only |
| 36 | Low Voltage Fault | Disable High-speed Driving |
| 38 | Incomplete weighing calibration error (Enable LSS) | Disable Lifting |
| 42 | Platform Left Turn Switch ON at Power-Up Message | Diagnostic Message Only |
| 43 | Platform Right Turn Switch ON at Power-Up Message | Diagnostic Message Only |
| 46 | Platform Joystick Enable Switch ON at Power-Up Fault | Disable Platform Control |
| 47 | Platform Joystick not in Neutral At Power-Up Message | Lift Slows to Elevated Speed |
| 52 | Forward Coil Fault | Lift and Drive Disabled |
| 53 | Reverse Coil Fault | Lift and Drive Disabled |
| 54 | Lift Up Coil Faul | Lift and Drive Disabled |
| 55 | Lift Down Coil Fault | Lift and Drive Disabled |
| 56 | Right Turn Coil Faul | Lift and Drive Disabled |
| 57 | Left Turn Coil Fault | Lift and Drive Disabled |
| 58 | General Brake Coil Fault (presently disabled because the brake output is optional) | Lift and Drive Disabled |
| 68 | Low Voltage Fault | All Functions are Disabled |
| 80 | Over 80% Load Warning | Warning Only |
| 90 | Over 90% Load Warning | Warning Only |
| 99 | Over 99% Load Warning | Warning Only |
| OL | Overloaded Platform Fault | All Functions are Disabled |
| LL | Machine Tilted Beyond Safe Limits Fault | Lift and Drive Disabled |

Manual

| | | |
|----|------------------------------|--|
| dL | Handle Disconnection Failure | The upper action are prohibited ; The lower lifting and falling are allowed. |
|----|------------------------------|--|

Fault Descriptions and Troubleshooting (6 Buttons)

| Display | Description |
|---------|--|
| 01 | System Initialization Fault: ECU may be malfunctioning, replace it. |
| 02 | System Communication Fault: Check communications cable connections and other wiring. If that does not resolve the problem, try replacing the PCU or ECU. |
| 03 | Invalid Option Setting Fault: Set appropriate option for this lift. |
| 04 | Invalid Machine Code: Invalid Option, set appropriate option for machine. |
| 09 | Invalid Function Configuration Setting Fault: Config ECU Function |
| 12 | Toggle Switch Open at Start-up Fault: Check wires to the Toggle Switch or look for a stuck Toggle Switch. |
| 18 | Pothole Guard Fault: Check that the pothole guards are extended, check the pothole limit switches. Check wires to the switches, check the down limit switch and connections |
| 27 | Lift Down Coil Fault (only for proportional valve): Check the connections to the Coil's terminals and make sure they are tight. If so, check the coil itself to see if it is open or shorted |
| 31 | Pressure Sensor Fault: Check the wiring to the sensor and then the sensor itself. Also check to make sure that the correct option is properly selected (or not) for load sensing |
| 32 | Angle Sensor Fault: Check the wiring to the sensor and then the sensor itself. Also check to make sure that the correct option is properly selected (or not) for load sensing |
| 35 | Calibration Data Error(Enable LSS): Check the Data of the weighing calibration. |
| 36 | Low Battery Alarm: Charge the battery. |
| 38 | Incomplete weighing calibration error (Enable LSS): Re-weighing calibration |
| 42 | Platform Left Turn Switch ON at Power-Up Message: Ensure that nothing is holding the Joystick Toggle Switches down. If OK, consider replacing the Joystick or PCU. |
| 43 | Platform Right Turn Switch ON at Power-Up Message: Ensure that nothing is holding the Joystick Toggle Switches down. If OK, consider replacing the Joystick or PCU. |
| 46 | Platform Joystick Enable Switch ON at Power Up Fault: Ensure that nothing is holding the Enable switch closed. If OK, consider replacing the Joystick or PCU. |
| 47 | Platform Joystick not in neutral at Power-Up Message: Make sure that the Joystick is in the neutral (upright) position. Check the neutral zone parameter setting in the LabView Programmer. If it's OK, consider replacing the Joystick or the PCU. |
| 52 | Forward Coil Fault: Check the connections to the Coil's terminals and make sure they are tight. If so, check the coil itself to see if it is open or shorted |
| 53 | Reverse Coil Fault: Check the connections to the Coil's terminals and make sure they are tight. If so, check the coil itself to see if it is open or shorted. |
| 54 | Lift Up Coil Fault: Check the connections to the Coil's terminals and make sure they are tight. If so, check the coil itself to see if it is open or shorted |

Manual

| | |
|----|--|
| 55 | Lift Down Coil Fault: Check the connections to the Coil's terminals and make sure they are tight. If so, check the coil itself to see if it is open or shorted |
| 56 | Right Turn Coil Fault: Check the connections to the Coil's terminals and make sure they are tight. If so, check the coil itself to see if it is open or shorted. |
| 57 | Left Turn Coil Fault: Check the connections to the Coil's terminals and make sure they are tight. If so, check the coil itself to see if it is open or shorted |
| 58 | General Brake Coil Fault: Check the connections to the Coil's terminals and make sure they are tight. If so, check the coil itself to see if it is open or shorted. |
| 68 | Low Voltage Fault: Check battery voltage and charge if necessary. Check the battery connections and tight or clean. Check the voltage to the ECU and PCU. |
| 80 | Over 80% Load Warning: Platform is getting close to its limit of weight. Consider not adding more load. Near maximum limit. Do not load extra weight. |
| 90 | Over 90% Load Warning: Platform is getting close to its limit of weight. Consider not adding more load |
| 99 | Over 99% Load Warning: Platform has reached its limit of weight. Do not add more load. |
| OL | Overloaded Platform Fault: Remove the excess load immediately. |
| LL | Machine Tilted Beyond Safe Limits Fault: If the machine is tilted, find a way to make it level. If the machine is level, check the wiring to the tilt sensor and then the sensor itself |
| dL | Handle Disconnection Failure: The wiring harness inside the PCU is damaged or has poor contact. |

Manual

Electrical Circuit (4 Button)

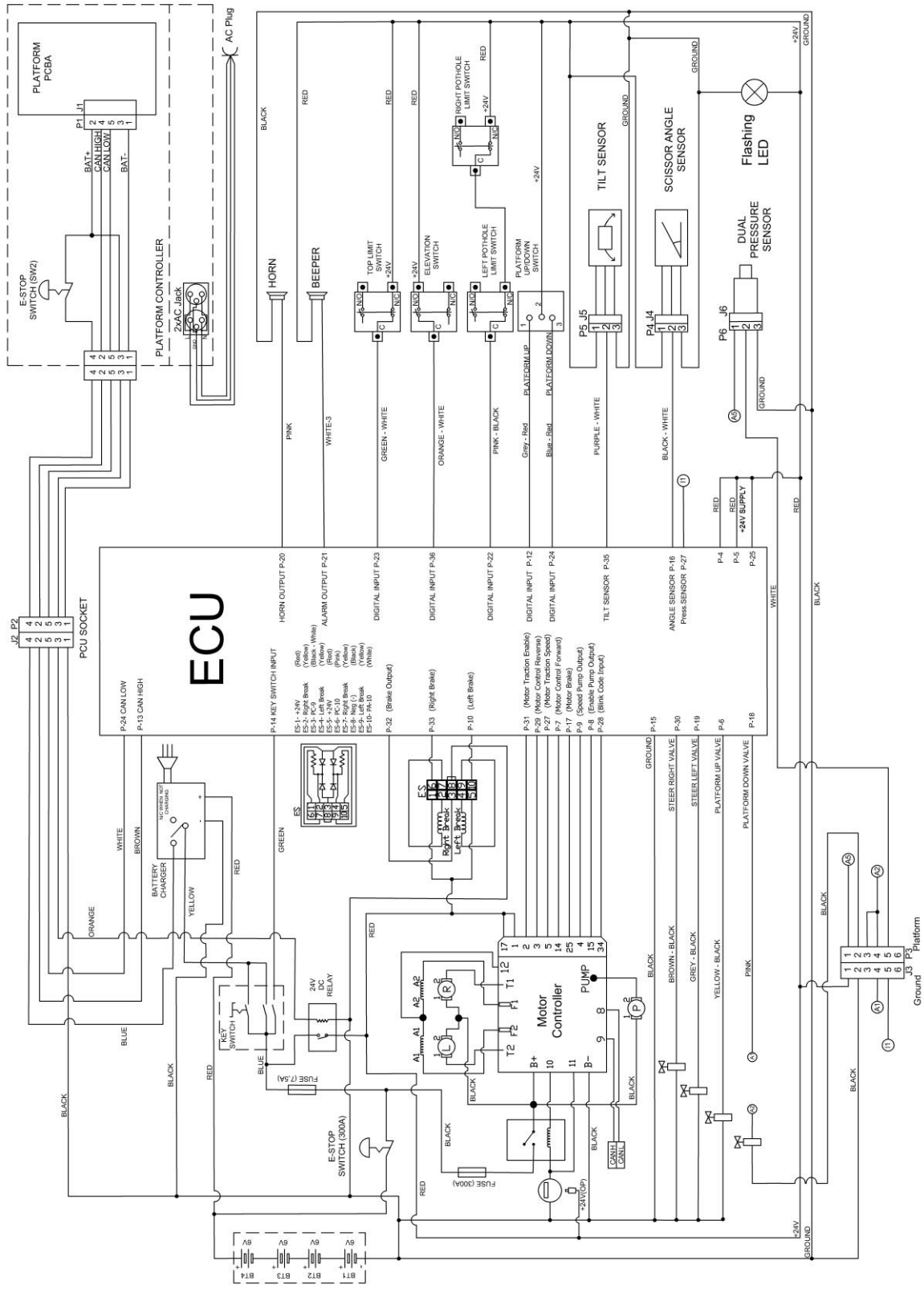

OUTPOWER THE GRAVITY.



Manual

Electrical Circuit (6 Button)

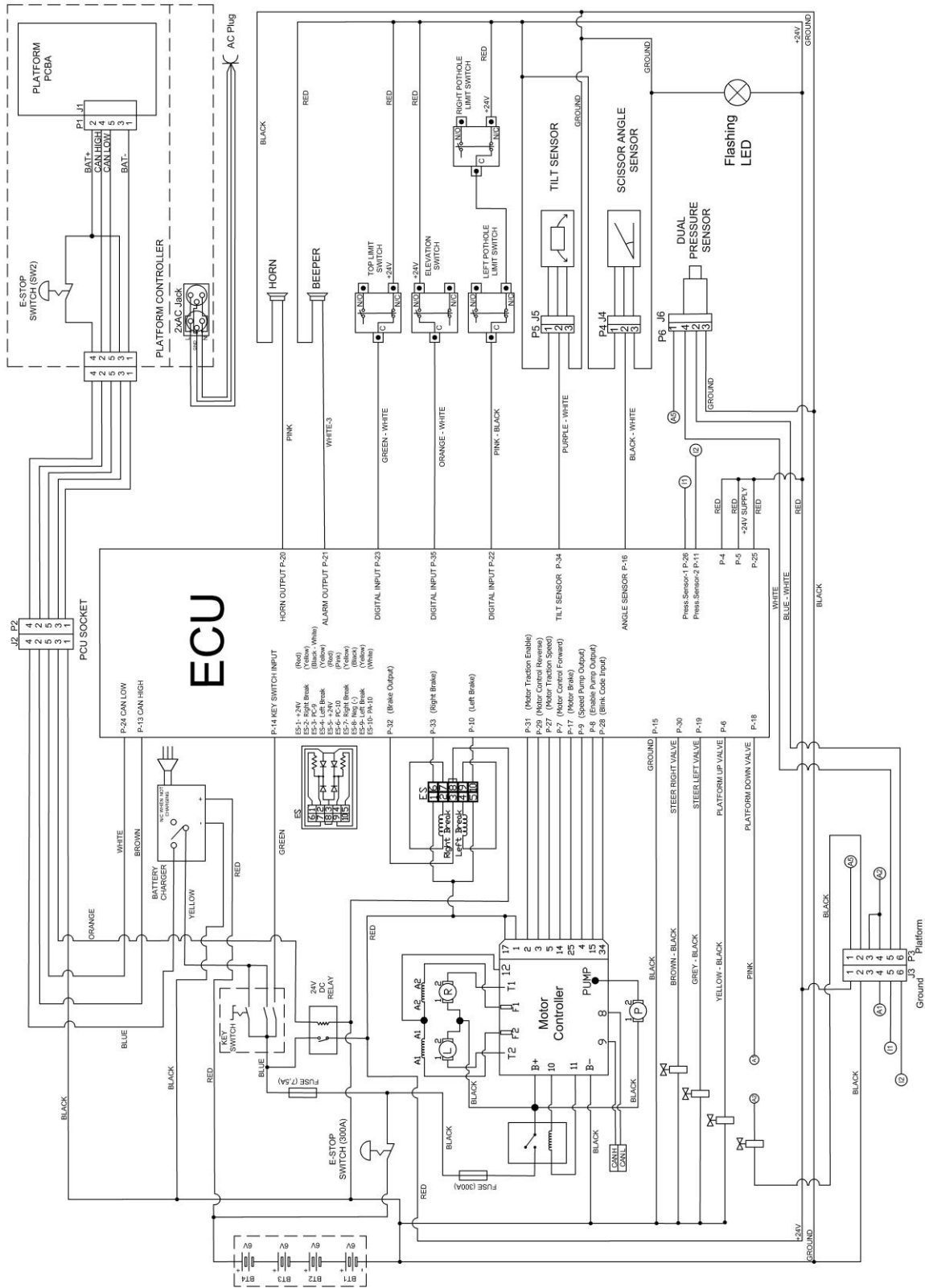

OUTPOWER THE GRAVITY.



Specifications

| MODEL | | UNITS | EL10-TE | EL8-TE |
|------------------------------|-----------------|------------------|---------------------|---------------------|
| WORKING HEIGHT | | m | 10,0 | 8,0 |
| PLATFORM FLOOR HEIGHT | <i>Elevated</i> | m | 8,0 | 6,0 |
| TOP GUARDRAIL HEIGHT | <i>Stowed</i> | m | 2,31 | 2,11 |
| HORIZONTAL REACH | <i>max</i> | m | 0,86 | 0,86 |
| WIDTH - OVERALL | | m | 0,80 | 0,80 |
| LENGTH - OVERALL | <i>Stowed</i> | m | 2,47 | 2,47 |
| MAXIMUM LIFT CAPACITY | | kg | 240 | 350 |
| MAXIMUM OPERATING WIND SPEED | | km / h | 45 | 45 |
| WHEEL BASE | | m | 1,86 | 1,86 |
| BATTERIES | | V / A/h | 4 x 6 / 225 | 4 x 6 / 225 |
| DRIVE SPEED | <i>Stowed</i> | km / h | 4,5 | 4,5 |
| DRIVE SPEED | <i>Elevated</i> | km / h | 0,6 | 0,6 |
| MAXIMUM VIBRATION | | m/s ² | 2,5 | 2,5 |
| TOEBOARD HEIGHT | | m | 0,02 | 0,02 |
| MACHINE WEIGHT | <i>Unloaded</i> | kg | 2045 | 1820 |
| NOISE PRESSURE | <i>Ground</i> | dBA | <70 | <70 |
| NOISE PRESSURE | <i>Platform</i> | dBA | <70 | <70 |
| PLATFORM LENGTH | | m | 2,31 | 2,31 |
| PLATFORM WIDTH | | m | 0,79 | 0,79 |
| CONTROLS | | V DC | 24, Proportional | 24, Proportional |
| BATTERY CHARGER | | V AC / A | 100 - 240 / 30 | 100 - 240 / 30 |
| TIRE SIZE | | mm | Solid 381 x 127 | Solid 381 x 127 |
| GRADEABILITY X, | <i>Stowed</i> | ° | 14 | 14 |
| | <i>Elevated</i> | ° | 2 | 2 |
| GRADEABILITY Y, | <i>Stowed</i> | ° | 9 | 9 |
| | <i>Elevated</i> | ° | 3 | 3 |

OUTPOWER THE GRAVITY.



Draft Declaration of Conformity

ELS LIFT



EC DECLARATION OF CONFORMITY (AT UYGUNLUK BEYANI)

Üretici / Manufacturer:

ELS LİFT MAKİNE SANAYİ TİCARET A.Ş.
Işıktepe OSB Bölgesi Lacivert Caddesi No:11 16140 Nilüfer/Bursa / TÜRKİYE
Tel : +90 224 241 30 90 Faks : +90 224 242 90 20 Web: www.elslift.com

Yetkili Temsilci/Servis / Authorized Agent/Service:

ELS LİFT MAKİNE SANAYİ TİCARET A.Ş.
Hürriyet Mah. Yakacak D-100 Kuzey Yanyol Cd. Sanku Makina No:49/1/1 Kartal/İstanbul / TÜRKİYE
Tel : +90 224 241 30 90 Faks : +90 224 242 90 20 Web: www.elslift.com

Aşağıda tanımlı makinanın Avrupa Yönetmeliklerine ve Uyumlaştırılmış Standartlara uygun olduğunu beyan ederiz.
Hereby declares that the product described below complies with the provisions of the following European Directives and Harmonized Standards.

Makina Tanımı / Description of Machine:

Makina Tipi / Type of Machine : Personel Yükseltici Platform / Personnel Lift Platform
Markası / Brand : ELS
Model Adı / Model Name :
Seri Numarası / Serial Number :

Uygulanan Yönetmelikler / Applicable Regulations:

2006/42/AT Makina Emniyeti Yönetmeliği ve 2014/30/AB Elektromanyetik Uyumluluk Yönetmeliği temel gereksinimlerini karşıladığını beyan ederiz.
Meets all the provisions of the 2006/42/EC Machinery Directive and 2014/30/EU Electromagnetic Compatibility Directive.

Uygulanan Standartlar / Applicable Standards:

EN 280-1:2022, EN 60204-1:2018, EN ISO 12100:2011, EN ISO 13849-1:2016

Tip İnceleme Sertifika No / Type Examination Certification Number:

1984-MCH-16-097

Onaylanmış Kuruluş – Adresi / The Notified Body - Address:

KİWA Belgelendirme Hizmetleri A.Ş. - İTOSB 9. Caddesi No:15 Tapedere Tuzla - İstanbul - Türkiye

CE Markası İyileştirme Yılı / Year of CE Marking:

Teknik Dosyayı Hazırlamak ve Muhafaza Etmekle Yetkili Kişi / Person Authorized to Compile Technical File:

Adı / Name : Gizem FERİK
Adresi / Address : Işıktepe OSB Bölgesi Lacivert Caddesi No:11 16140 Nilüfer/Bursa / TÜRKİYE

Üretici ya da Yetkili Temsilci Adına İmzalayan / Signed on Behalf of The Manufacturer or Authorized Agent:

Adı / Name :
Görevi / Position :
Yer-Tarih / Place-Date :
İmza / Signature :

ELS LİFT MAKİNE Sanayi Ticaret A.Ş.
Işıktepe OSB Mah. Lacivert Cad. No: 11 Nilüfer/Bursa
+90 224 241 30 90 www.elslift.com / info@elslift.com

ELS

ELS/TS/013/00
Yayın Tarihi: 01.01.2009
Revizyon Tarihi: 00/

ELS LIFT

LIMITED OWNER WARRANTY

ELS Lift Makina Sanayi Ticaret A.Ş. warrants its equipment to the original purchaser against defects in material and/or workmanship under normal use and service for one (1) year from date of registered sale or date the unit left the factory if not registered. ELS Lift Makina Sanayi Ticaret A.Ş. further warrants the structural weldments of the main frame and scissor arms to be free from defects in material or workmanship for two (2) years from date of registered sale or date unit left the factory if not registered. Excluded from such warranty is the battery(s). Warranty claims within such warranty period shall be limited to repair or replacement, ELS Lift Makina Sanayi Ticaret A.Ş.'s option, of the defective part in question and labor to perform the necessary repair or replacement based on ELS Lift Makina Sanayi Ticaret A.Ş.'s then current flat rate, provided the defective part in question is shipped prepaid to ELS Lift Makina Sanayi Ticaret A.Ş. and is found upon inspection by ELS Lift Makina Sanayi Ticaret A.Ş. to be defective in material and/or workmanship. ELS Lift Makina Sanayi Ticaret A.Ş. shall not be liable for any consequential, incidental or contingent damages whatsoever. Use of other than factory authorized parts; misuse, improper maintenance, or modification of the equipment voids this warranty. The foregoing warranty is exclusive and in lieu of all other warranties, express or implied. All such other warranties, including implied warranties of merchantability and of fitness for a particular purpose, are hereby excluded. No Dealer, Sales Representative, or other person purporting to act on behalf of ELS Lift Makina Sanayi Ticaret A.Ş. is authorized to alter the terms of this warranty, or in any manner assume on behalf of ELS Lift Makina Sanayi Ticaret A.Ş. any liability or obligation which exceeds ELS Lift Makina Sanayi Ticaret A.Ş.'s obligations under this warranty.